

# HIAB XS 055 Range 4-6 tm

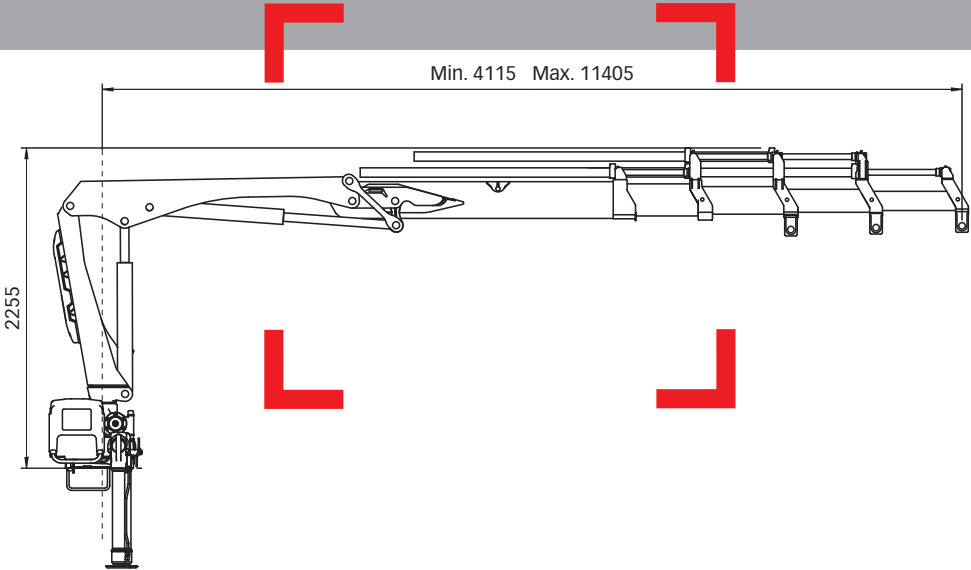

Basic data

# HIAB XS 055 Basic data

## Technical data

	B-1 CL	B-2 Duo	D-3 HiDuo	D-4 HiDuo
Max. lifting capacity (kNm)	45	45	49	47
Outreach - hydraulic extensions (m)	5.5	7.3	9.3	11.3
Outreach - manual extensions (m)	9.1	9.1	11.2	-
Outreach / lifting capacity, standard (m / kg)	2.3 / 1980	2.7 / 1760	2.9 / 1720	3.1 / 1560
	3.8 / 1200	3.8 / 1220	4.0 / 1240	4.1 / 1200
	5.4 / 840	5.4 / 840	5.5 / 880	5.6 / 820
	-	7.2 / 620	7.3 / 640	7.3 / 580
	-	-	9.3 / 490	9.3 / 430
	-	-	-	11.2 / 350
Slewing angle	410°	410°	410°	410°
Height in folded position (mm)	1900	1900	1900	1900
Width in folded position (mm)	2075	2160	2150	2170
Installation space needed (mm)	565	565	650	650
Weight - "standard" crane without stabilizers (kg)	730	810	880	950
Weight - stabilizer equipment (kg)	105 - 160	105 - 160	105 - 160	105 - 160

## HIAB XS 055 D-4 HiDuo

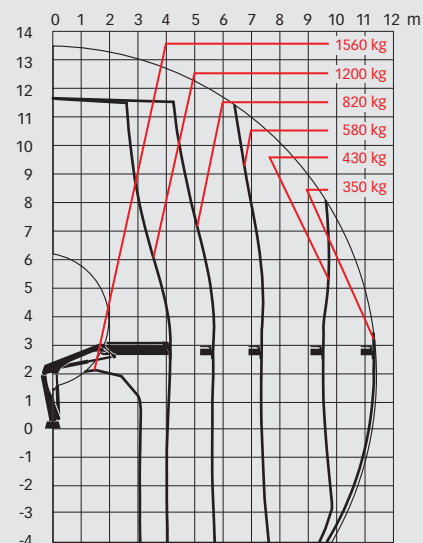
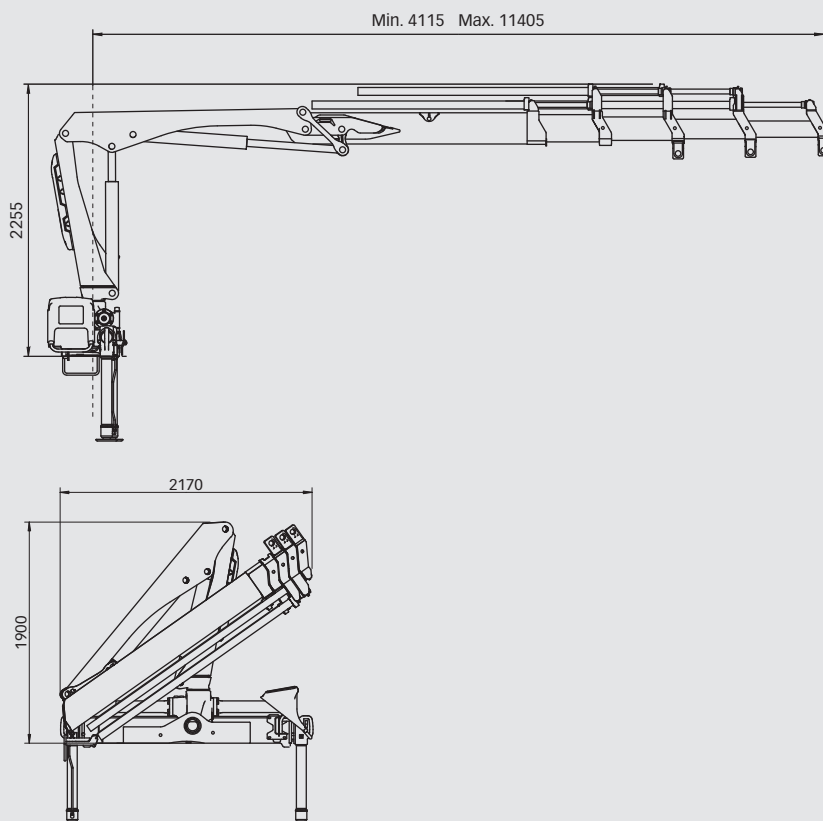

### Disclaimer

Hiab cranes have been built to meet the highest standards of safety and service life and have been thoroughly tested. Strength calculations for this model have been carried out in accordance with EN13001. Hiab's certified Quality Assurance System complies with the ISO 9001. Some of the items in our literature may be extra equipment. Certain applications may require an official permit. We reserve the right to change technical specifications without prior notice. Hiab cranes produced for EU-countries are CE-marked and comply with the European Standard EN 12999.